

Features

- ✧ Built-in microprocessor samples and collects data in real time.
- ✧ Rate of rise and fixed temperature alarm mode.
- ✧ Standard: UL 521.

Description

C-9103(UL) Conventional Rate of Rise and Fixed Temperature Heat Detector (the detector) is non-addressable. With built-in microprocessor, it is fixed with highly reliable fire judging program and works stably.

When the detector checks fire signal, it can change its own current to transmit fire signal to control panel or interface module. The detector keeps illuminating fire LED to indicate fire status until resetting. Used together with P-9907 Active End of Line Unit (AEOL), it can connect with compatible fire alarm control panel to conduct the processing of detector signals.

Connections and Wiring

The orientation base is shown in Fig. 2.

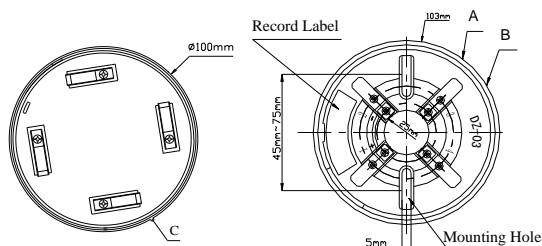

Fig. 1

Fig. 2

The bottom and orientation base of the detector are shown in Fig.1 and 2. There are four terminals with numbers on the base, "1" connects with the anode of the output end of compatible controller, "2" connects with the power anode of the next detector as output (terminal No. "1"), "3" connects with the power cathode of the next detector (terminal No. "3") and the cathode of the output end of compatible controller, "4" doesn't connect to any wires but is used to fix the detector accessarily.

Recommended Wiring:

1.0mm² or above fire cable for all terminals, laid through metal conduit or flame-proof conduit, subject to local codes.

Installation

There are location elements on the detector and the orientation base to ensure there is only one installing position. There are two marks on point A and B of the orientation base, and a mark on point C of the side face of bottom of the detector. When installing, aligning the mark C of the detector to point A of the orientation base, rotate the detector clockwise to point B, then the detector is installed.



Mounting of the detector is shown in Fig. 3.

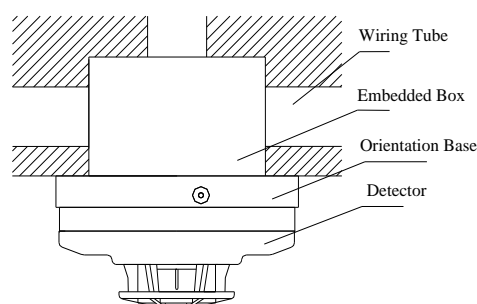

Fig. 3

Application

Warning: The detector should be connected with fire alarm control panel or other devices with current limit function. Otherwise the detector may be destroyed by too heavy alarm current.

A 4.7k/1w terminal resistor can be connected between terminal "2" and "3" of the last base in a loop. System connection is shown in Fig. 4.

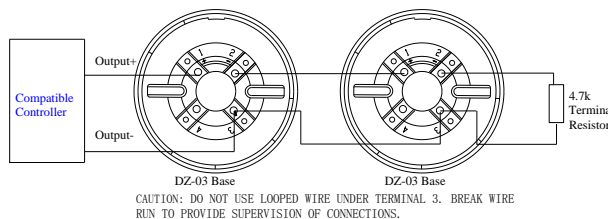

Fig. 4

Maintenance

1. Before installation, the detector should be kept well and adopted the corresponding measures for dust-proof, damp-proof and corrosion-proof.
2. The dust cover cannot be removed until the project has been plugged into usage.
3. The detector should be cleaned at least once each year.
4. Before cleaning, notify relative departments that the system is undergoing maintenance and will be out

of service. Disable the zone or system in maintenance to avoid unwanted alarms.

5. After cleaning, install the detector back and test again. Notify relative departments that the system is back into operation.

6. Do fire simulation test every half a year to make sure the detector works normally.

Specification

Operating Voltage	12VDC~28VDC
Standby Current	≤60μA
Alarm Current	≤30mA
Initiating Time:	≤10s
Alarm Reset:	Instantaneous Cut out (5s MAX, 2.5VDC MAX)
Alarm Confirming LED	Red, not lit when in normal operation, constantly lit when alarming
Maximum Ripple Voltage	4V(peak-to-peak value)
Sensitivity	Fixed Temperature Setpoint:135°F (57°C) Rate of Rise Detection: 15°F/min (8.3°C/min)
Wiring	Connecting with the power cable by polarized two-wire
Ingress protection Rating	IP33
Ambient Temperature	32°F (0°C)~100°F (37.8°C) (UL 521)
Relative Humidity	≤95%, non condensing
Material and Color of Enclosure	ABS, white (RAL 9010)
Dimensions	Diameter: 100mm High: 45mm (without base)
Mounting Hole Spacing	45mm~75mm
Weight	About 120g

Accessories and Tools

Module	Name	Remarks
DZ-03	Orientation base	Supplied separately

Limited Warranty

This detector is approved by UL as a recognized component. It's strongly recommended that fire alarm control panel manufacturers intending to use this detector in their fire alarm systems to verify system compatibility before application in order to avoid system failure.

GST warrants that the product will be free from defects in design, materials and workmanship during the warranty period. This warranty shall not apply to any product that is found to have been improperly installed or used in any way not in accordance with the instructions supplied with the product. Anybody, including the agents, distributors or employees, is not in the position to amend the contents of this warranty. Please contact your local distributor for products not covered by this warranty.

This Data Sheet is subject to change without notice. Please contact GST for more information or questions.

Gulf Security Technology Co., Ltd.

No. 80, Changjiang East Road, QETDZ, Qinhuangdao, Hebei, P. R. China 066004

Tel: +86 (0) 335 8502434 Fax: +86 (0) 335 8502532

service.gst@fs.utc.com www.gst.com.cn