

DC-M9102

Conventional Photoelectric Smoke Detector



Description

DC-M9102 is Conventional Photoelectric Smoke Detector by light-scattering technology, can build up fire alarm system together with fire alarm panel and other alarm devices. The detector is suitable for hotel, restaurant, office building, school, bank, warehouse, library, computer room, switch room, and etc.

Features and Benefits

- Strong environmental adaptability due to drift compensation
- Self-diagnostic
- Reed switch test
- Dirty chamber checking
- Fire LED allows 360° viewing
- LED indication for both fire and normal status
- LED indication for normal status can be turned off by handheld programmer
- Remote indicator output
- Removable innovative sensing chamber, easy for maintenance

Terminals and Installation Holes

Below figures show the detector bottom and terminals of the base.

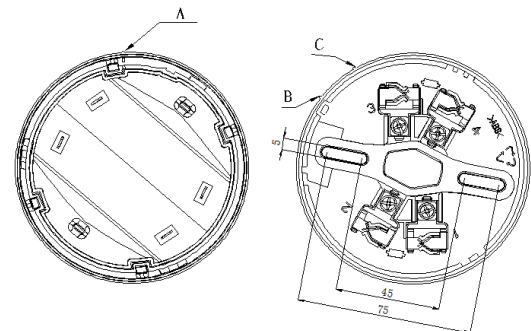

There are four terminals with marks on the base.

- 1: positive IN
- 2: positive OUT
- 3: negative IN and OUT
- 2: Positive terminal of remote indicator
- 4: Negative terminal of remote indicator

Recommended Cabling

17AWG ~ 14AWG fire cable is recommended, but subject to local codes.

Application

Warning:

The detector should be connected with fire alarm control panel or other devices with current limit function. Otherwise the detector may be damaged by too heavy alarm current.

The alarm current depends on the current limit of the control panel or interface unit.

The detector is compatible with I-M9300 and DI-M9319 interface module. The typical connection is shown below.

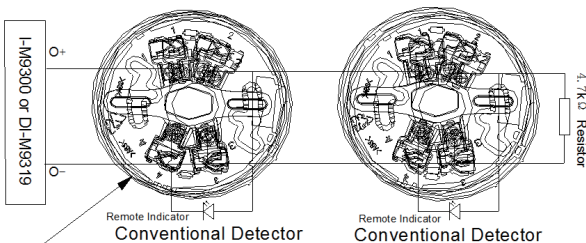

DO NOT USE LOOPED WIRE UNDER TERMINAL 3. BREAK WIRE RUN TO PROVIDE SUPERVISION OF CONNECTIONS

Below table shows relative setting codes for working modes. Factory defaults at Normal LED.

Detector Code	Polling LED
1	Normal
129	OFF

Technical Specification

Operating Voltage	24VDC
Standby Current	≤ 60μA
Alarm Current	≤ 55mA
LED Indicator	Red, periodically flash once in polling when the status is set to "ON"; don't illuminate when the status is set to "OFF". Periodically flash twice in fault or sensing chamber dirty; illuminate in alarming.
Remote Indicator Output	Polarity-sensitive output, directly connecting with remote indicator (built in 10k resistor in series, max. output current is 2mA); don't illuminate when in normal; flash in alarming.
Maximum Ripple Voltage	2V (peak-to-peak)
Alarm Reset	Instantaneous power down (Min.10sn, Max. 1.0VDC)
Sensitivity and range	1.23%~3.20% per ft
Operating Temperature	14°F (-10°C) - 131°F (+55°C)
UL Temperature Range	32°F (0°C) - 100°F (37.8°C)
Relative Humidity	≤95%, non-condensing
Material of Enclosure	ABS White (RAL 9016)
Ingress Protection Rating	IP2X
Dimensions	Diameter: 100mm Height: 44.5mm (without base)
Mounting Hole Distance	45mm-75mm
Weight	110g

Certificates and Compliance

- Standards: UL 268
- Listed by UL
- WEEE & RoHS Compliant

Order Information

Part No.	DC-M9102
Device Name	Conventional Photoelectric Smoke Detector
Product No.	10104832
Compatible Products	DI-M9319 Zone Monitor Module

Accessories and Tools



Part No.: DB-M01
Device name: Common Detector Base
Product No.: 30205767



Part No.: C-9314P
Device name: Remote Indicator
Product No.: 10102339



Part No.: P-9910B
Device name: Handheld Programmer
Product No.: 10104894